

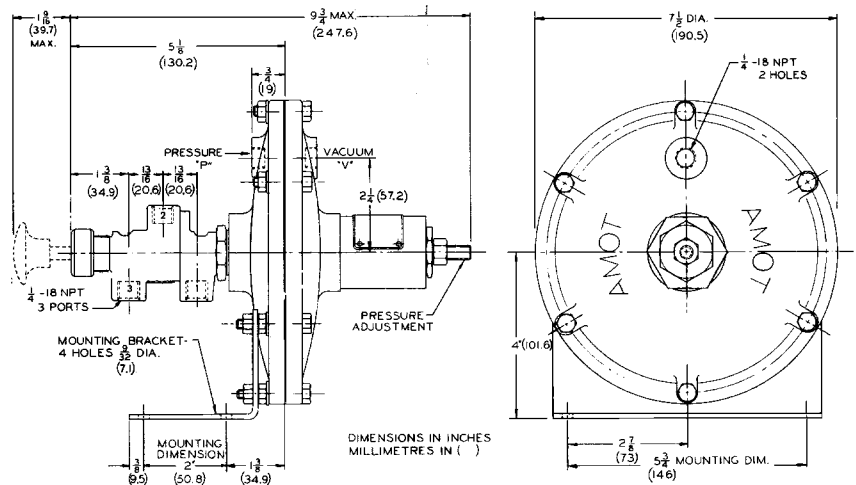

Model 4047



FEATURES

- 3-WAY VALVE HAS BALANCED FORCE DESIGN
- PRESSURE CAN BE APPLIED AT ANY PORT
- BUNA N "TADPOLE" SEALS ARE EASILY REPLACED
- BUBBLE-TIGHT SEALS WITH CENTER DEAD SPOT - NO PORT OVERLAP
- GULFPROOFING STANDARD

APPLICATIONS

- SENSE LOW PRESSURE OR VACUUM OF WATER, AIR, NATURAL GAS, OIL, AND MORE...
- DETECTION OF OVERLOAD ON GAS ENGINES
- SENSING OF VACUUM IN INTAKE AIR MANIFOLD

Model 4047 is used as a 2-way or 3-way high capacity, low pressure valve for settings from 0.1 psi falling to 11.2 psi rising over several ranges. Applications include sensing low pressure low pressure gas, water, fuel, oil, or for liquid level sensing and control. By piping to the vacuum port, the valve can be used to sense vacuum pressure from 0.1 psi falling. The 4047 can detect overload on gas engines by sensing the vacuum pressure in the intake manifold.

VALVE OPERATION

2-WAY Valve to open on rising pressure

Port 1 must be plugged. Rising pressure will open Port 2 to Port 3 above the trip point.

Valve to open on falling pressure

Port 3 must be plugged. Falling pressure will open Port 2 to Port 1 below the set trip point.

3-WAY Valve operation for 3-way action is identical with that for 2-way except that there will be no plugged ports. On valves set to trip on rising pressure, Port 1 will open to Port 2 until just below the trip point. Port 3 will open to Port 2 at the trip point. On falling pressure, Port 3 will close first. Then Port 1 will open to Port 2.

AMOT Model 4047 has a "dead spot" in the exact center position, which prevents the overlapping of Ports 1 and 3. Because of this, Ports 1 and 3 will not open and close simultaneously at the trip point.

ADJUSTMENT

The trip adjustment is made by turning Screw (23) one way or the other from the original position after loosening Locknut (24). Turning clockwise will compress Loading Spring (34) and raise the point at which Control Plunger (29) will move to the right on an increase in pressure. Fine adjustment may be made by turning Screw (33) only on the unit with automatic reset

AMOT designs and tests all products to ensure that high quality standards are met. This product should last for many years. For good product life, carefully follow AMOT's installation and maintenance instructions; failure to do so could result in damage to the equipment being protected.

INSTALLATION

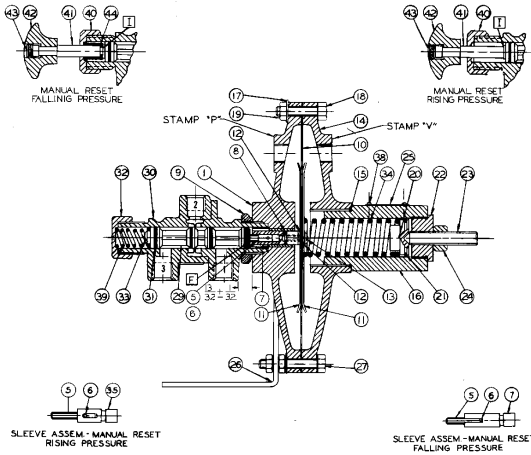

The Model 4047 valve can be mounted in any position but it is best applied horizontally as shown. When manual reset on falling pressure is included, the control can be mounted with the reset knob down. When manual reset on rising pressure is included, the control can be mounted with the reset knob up. (See illustration above) It is important that these instructions be followed. It is only the frictional force of the seal rings that holds Valve Spool (29) in position and machine vibration can cause the valve to reset if it is not mounted properly.

Control pressure and sensed pressure sources and interconnecting tubing must be free of dirt, chips, rust and other contaminants. Apply a quality thread sealant such as Loctite Pipe Sealant to pipe connections. Maximum continuous control pressure and the proof pressure on the diaphragm must be kept within the specifications limits or the warranty will be void.

OPERATING RANGES (See table A of the Model Coding)

1. When manual reset is used the lower end of range will be raised approximately 0.2 psi.
- ** 2. Differential pressure will be less at the lower end of the range.
- ** 3. Differential pressure is the change in sensed pressure above or below the trip point, to move the 3-way valve and cause an AMOT 2400D Indicating Relay to change from red to green with 60 psi control pressure in the valve and system.

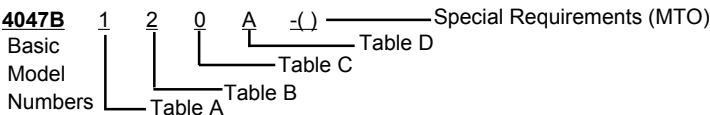

Table A Pressure Range Code Number				Table B Thread & Finish Code Number			Table C Reset Type Code Number		Table D Seal Material Code Number	
Code No.	Tripping Pressure Range		Reset Differential Pressure**	Code No.	Thread	Finish	Code No.	Description	Code No.	Seal Material
	Rising psi	Falling psi								
1	0.4 - 1.3 (2.8-9.0)	1.0 - 1.0 (.69 - 6.9)	.2 - .3 (1.4 - 2.0)				0	Automatic Reset		
2	0.8 - 7.0 (5.6-48.0)	0.4 - 6.2 (2.8 - 43.0)	.4 - .8 (2.8 - 5.6)	2	NPT	Gulfproof	1	Manual Reset (falling pressure)	A	Buna N (Standard)
3	2.5 - 11.2 (17.0-77.0)	2.0 - 10.0 (13.8 - 69.0)	.5 - 1.2 (3.4 - 8.3)				2	Manual Reset (rising pressure)	B	Viton

AMOT USA
401 First Street
Richmond, CA 94801
Tel: +1 510 236-8300
Fax: +1 510 234-9950

AMOT
Western Way
Bury St. Edmunds IP33 3SZ
Suffolk England
Tel: +44 1284 762222
Fax: +44 1284 760256

AMOT SINGAPORE
10 Eunos Road 8 # 12-06
Singapore Post Centre
Singapore 408600
Tel: +65 6293 4320
Fax: +65 6293 3307

When disassembling the unit to replace the seals and diaphragm, it is important to mark the position of the housings and take a measurement from Diaphragm Body Boss (1) and end of Valve Body (30) so they may be reassembled to the same position and maintain the valve port positioning. It is also important to keep Spool (29) from turning during disassembly and reassembly.

Service Kit No. 9169X002 Viton				Service Kit No. 9169X002 Viton			
Ref.	Qty.	Description	Part	Ref.	Qty.	Description	Part
8	1	O-Ring	1625	8	1	O-Ring	1625L001
10	1	Diaphragm	293	10	1	Diaphragm	2931L002
12	2	Seal	714L002	12	2	Seal	714L002
15	1	O-Ring	516	15	1	O-Ring	516
21	1	O-Ring	270	21	1	O-Ring	270
31	4	Seal Ring	7896L002	31	4	Seal Ring	7896L002

SPECIFICATIONS

Valve Body and Diaphragm Housing Gulfproofed Aluminum
 Valve Spool Glass Reinforced Ryton
 Standard Seals and Diaphragm Buna N
 Maximum Operating
 Pressures at Ports 1, 2, and 3 125 psi (860 kPa)
 Maximum Continuous Control
 Pressure at Diaphragm 20 psi (138 kPa)
 Proof Pressure - Diaphragm 30 psi (207 kPa)
 Maximum Temperature 150°F (66°C)
 Valve Free Flow Area Equivalent
 to 9/32" Diameter Port C = 1.2
 Net Weight 5 lbs. (2.26 kg)

MAINTENANCE

Properly applied and installed, Model 4047 requires minimal maintenance. Unless leakage or other problems are noticed sooner, an inspection of the units at yearly intervals is adequate to detect and make provision for normal wear and preventative maintenance. It is recommended that the valve be checked monthly if possible for proper functioning by simulating an unsafe condition. When installing Diaphragm (10) it is necessary to keep the bolt holes lined up to avoid any binding action of Pin (6) against the sides of the slot of Sleeve (7). This binding action would increase the frictional forces which would affect the trip action pressure setting. Prior to reassembly, clean all parts thoroughly. Fill spool grooves with Dow Corning No. 33 Grease (AMOT No. 911L001). Install new seal rings by first inserting the thin tail section of the ring into one side of the groove. Then work around the ring until it is uniformly positioned. Remove excess grease. Also coat the metal surfaces that contact the diaphragm with grease before installing it.