

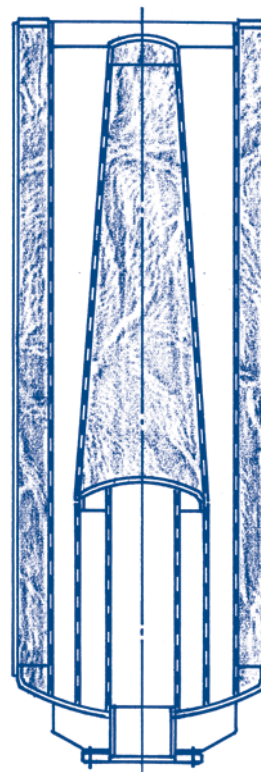

## Specialists in Industrial Silencing

Stoddard Silencers of Canada Inc.  
491 Brimley Rd. Unit 1, Scarborough, Ontario, Canada M1J 1A4  
Telephone (416) 291-4390 • FAX (416) 291-4791  
E-Mail - [info@stoddardsilencers.com](mailto:info@stoddardsilencers.com)  
Web page - [www.stoddardsilencers.com](http://www.stoddardsilencers.com)

# VENT SILENCERS





# Vent Silencers

**B21  
B13  
B14**

## Design

### Model B21

Absorption style silencer employing a single stage diffuser and containing a perforated tube surrounded by acoustic material packed to a controlled density to achieve silencing.

### Model B13 and B14

Absorption type silencers employing a single or multi-stage diffuser, and containing an acoustic core to decrease high frequency noise.

## Construction

All welded construction of sheet and plate steel. Absorption material appropriate for operation conditions. Exterior surfaces are prime coated. Flanges are drilled to match 125 lb. American Standard Flanges. Side connections, mounting brackets, flanged outlet nozzle, or special paint available at extra cost.

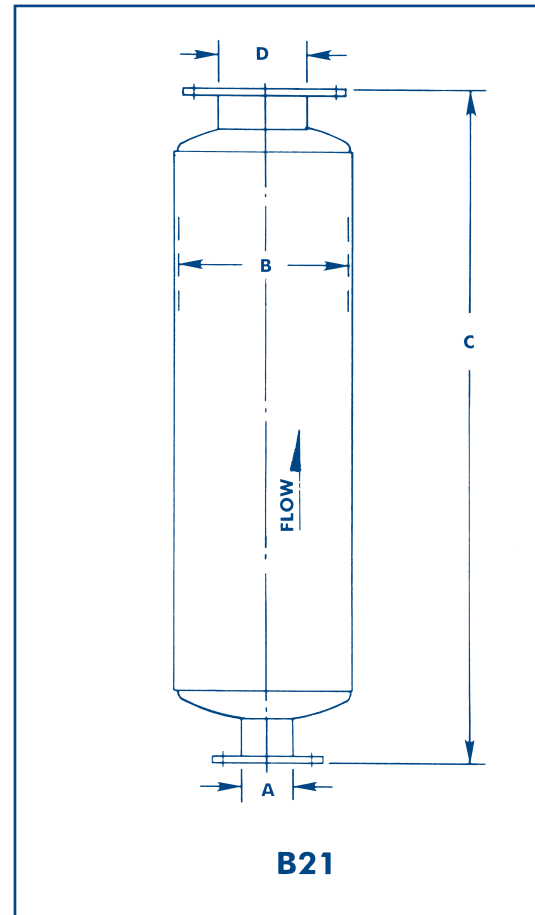

Octave Band Center Frequency (HZ)	63	125	250	500	1K	2K	4K	8K
Typical Attenuation (dB) Model B21	8	10	14	19	30	33	30	28
Typical Attenuation (dB) Model B13	14	21	25	31	35	40	38	35
Typical Attenuation (dB) Model B14	18	23	29	38	44	47	45	40

Model	A	B	C	D	Wt.
B21-5	2	12	66	5	96
B21-6	3	12	78	6	125
B21-8	4	14	86	8	150
B21-10	6	16	106	10	230

Model	A	B	C	Wt.
B13-8	4	18	45	180
B13-10	5	20	50	300
B13-12	6	24	60	420
B13-14	6	26	65	585
B13-16	8	30	68 <sup>1</sup> / <sub>2</sub>	822
B13-18	8	30	75	900
B13-20	10	36	90	1530
B13-22	10	36	97	1649
B13-24	12	42	106	2014
B13-26	12	42	106	2176
B13-28	14	48	112	2464
B13-30	14	48	121	2662
B13-36	18	60	150	4950
B13-42	22	66	171	6840
B13-48	24	72	172	7568
B13-54	26	78	196	9212
B13-60	30	84	210	10920

Model	A	B	C	Wt.
B14-8	4	18	55	220
B14-10	5	20	67 <sup>1</sup> / <sub>2</sub>	405
B14-12	6	24	78	546
B14-14	6	26	84	756
B14-16	8	30	92 <sup>1</sup> / <sub>2</sub>	1110
B14-18	8	30	97 <sup>1</sup> / <sub>2</sub>	1170
B14-20	10	36	117 <sup>3</sup> / <sub>8</sub>	1997
B14-22	10	36	129 <sup>5</sup> / <sub>8</sub>	2200
B14-24	12	42	130	2470
B14-26	12	42	130	2530
B14-28	14	48	143	3146
B14-30	14	48	157	3454
B14-36	18	60	194 <sup>1</sup> / <sub>2</sub>	6418
B14-42	22	66	215	8600
B14-48	24	72	232	10208
B14-54	26	78	256	12032
B14-60	30	84	258	13416

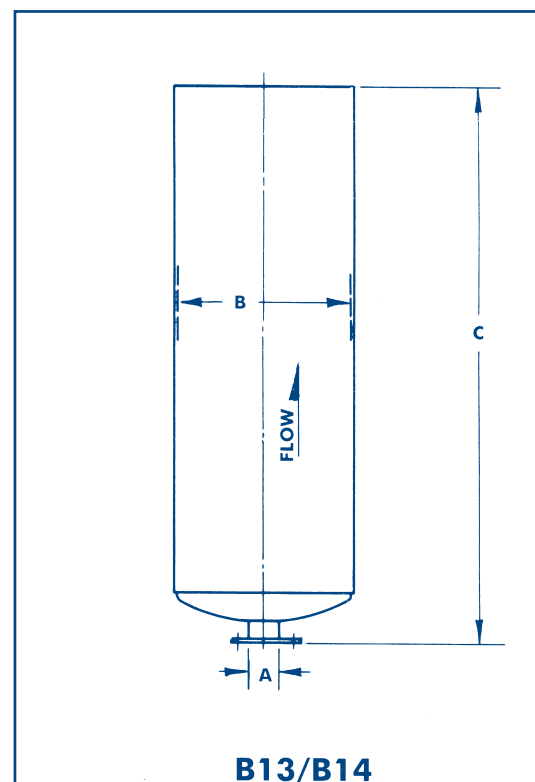

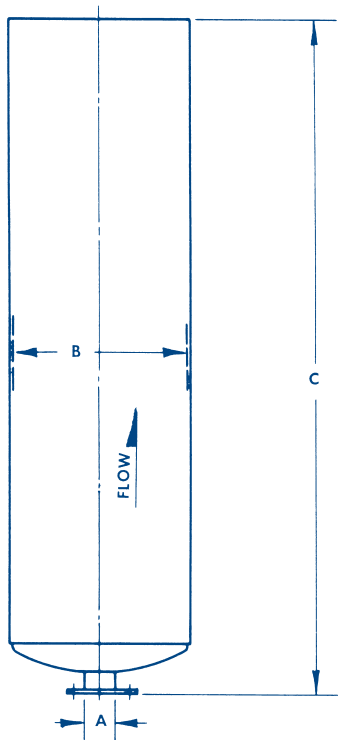

**B15**

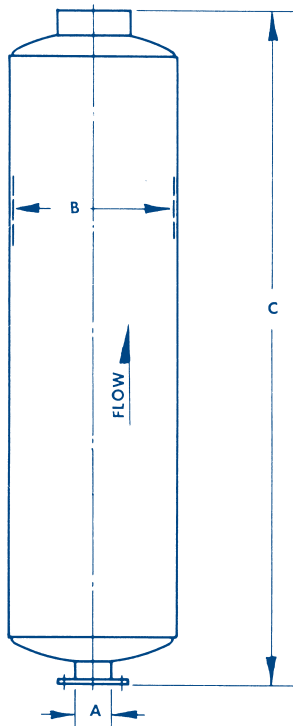

**B34**

# B15 B34

## Vent Silencers

### Design

#### Model B15

Absorption type silencer employing a single or multi-stage stage diffuser and containing an acoustic core to decrease high frequency noise.

#### Model B34

A multi-chamber silencer employing a single stage diffuser and absorption section to effectively treat both high and low frequencies.

### Construction

All welded construction of sheet and plate steel. Absorption material appropriate for operating conditions. Exterior surfaces are prime coated. Flanges are 150 lb. ANSI RF SO. Side connections, mounting brackets, flanged outlet nozzle, or special paint available at extra cost.

Octave Band Center Frequency (Hz)	63	125	250	500	1K	2K	4K	8K
Typical Attenuation (dB) <b>Model B15</b>	22	25	33	47	53	55	53	47
Typical Attenuation (dB) <b>Model B34</b>	26	33	36	38	40	38	33	26

Model	A	B	C	Wt.
B15-4	2	10	45	120
B15-5	2	12	53	150
B15-6	3	16	60	180
B15-8	4	18	67	268
B15-10	5	20	79 <sup>1</sup> / <sub>2</sub>	477
B15-12	6	24	95 <sup>3</sup> / <sub>4</sub>	670
B15-14	6	26	104	936
B15-16	8	30	112	1344
B15-18	8	30	116 <sup>1</sup> / <sub>2</sub>	1398
B15-20	10	36	129 <sup>5</sup> / <sub>8</sub>	2201
B15-22	10	36	144	2448
B15-24	12	42	154	2926
B15-26	12	42	168	3192
B15-28	14	48	179	3938
B15-30	14	48	193	4246
B15-36	18	60	216	7128
B15-42	22	66	255	10200
B15-48	24	72	288	12672
B15-54	26	78	316	14852
B15-60	30	84	336	17472

Model	A	B	C	Wt.
B34-4	2	12	60	90
B34-5	2 <sup>1</sup> / <sub>2</sub>	14	67	145
B34-6	3	16	73	190
B34-8	4	18	80	230
B34-10	5	22	93	440
B34-12	6	26	112	575
B34-14	6	30	125	920
B34-16	8	30	135	965
B34-18	8	36	150	1380
B34-20	10	42	176	1930
B34-22	10	42	176	2115
B34-24	12	54	190	2770
B34-26	12	54	216	3590
B34-28	14	60	229	4325
B34-30	14	60	247	4600
B34-36	18	72	280	8050
B34-42	22	84	332	9625
B34-48	24	96	370	13775
B34-54	24	108	397	19150
B34-60	30	114	437	20400



## Specialists in Industrial Silencing

Stoddard Silencers of Canada Inc.  
 491 Brimley Rd Unit 1, Scarborough, Ontario Canada M1J 1A4  
 Telephone (416) 291-4390 • FAX (416) 291-4791  
 E-Mail - info@stoddardsilencers.com  
 Web page - www.stoddardsilencers.com